

McIntosh

MC 2300

POWER AMPLIFIER

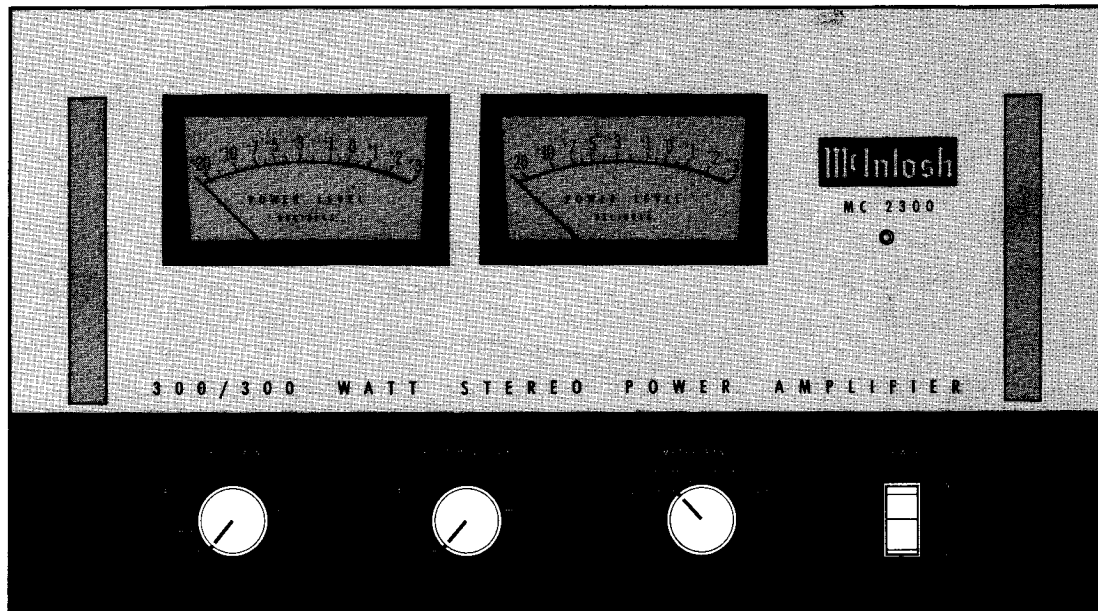

SERVICE INFORMATION

STARTING WITH SERIAL NO. 1Y001

McINTOSH LABORATORY INC. 2 CHAMBERS STREET BINGHAMTON, NEW YORK

MC 2300

ELECTRICAL SPECIFICATIONS

POWER OUTPUT:

- Stereo - 300 RMS watts continuous per channel into 0.5, 1, 2, 4, 8 or 16 ohms both channels operating.
- Mono - 600 RMS watts continuous into 0.25, 0.5, 1, 2, 4, or 8 ohms.

HARMONIC DISTORTION:

- Stereo - Less than 0.25% at 300 watts output from 20Hz to 20kHz both channels operating. Typical performance is less than 0.1% at rated power. Distortion decreases as output power is reduced.

INTERMODULATION DISTORTION:

- Stereo - Less than 0.25% if instantaneous peak power output is 600 watts or less per channel with both channels operating for any combination of frequencies 20Hz to 20kHz.
- Mono - Less than 0.25% if instantaneous peak power output is 1200 watts or less for any combination of frequencies 20Hz to 20kHz.

FREQUENCY RANGE:

- 20Hz to 20kHz +0, -0.5dB at rated power for all outputs; except 0.5 and 2 ohms, -1dB.
- 12Hz to 35kHz +0, -1.5dB at one-half of rated power.

NOISE AND HUM:

- 90dB or more below rated output.

OUTPUT IMPEDANCE:

- Stereo - 0.5, 1, 2, 4, 8, and 16 ohms.
- Mono - 0.25, 0.5, 1, 2, 4 and 8 ohms.

OUTPUT VOLTAGES:

- Stereo - 12, 17.5, 24.5, 35, 49 and 70 volts.
- Mono - 12, 17.5, 24.5, 35, 49 and 70 volts.

DAMPING FACTOR:

- | | |
|------------------------|-----------------------|
| 27 at 0.5 ohms output. | 21 at 4 ohms output. |
| 50 at 1 ohm output. | 14 at 8 ohms output. |
| 29 at 2 ohms output. | 13 at 16 ohms output. |

INPUT IMPEDANCE:

- 200,000 ohms.

INPUT SENSITIVITY:

- 0.5 volts. Level controls provided for higher input voltage.

POWER REQUIREMENTS:

- 120 volts AC 50/60Hz, 160 watts at zero signal output. 1400 watts at rated output.

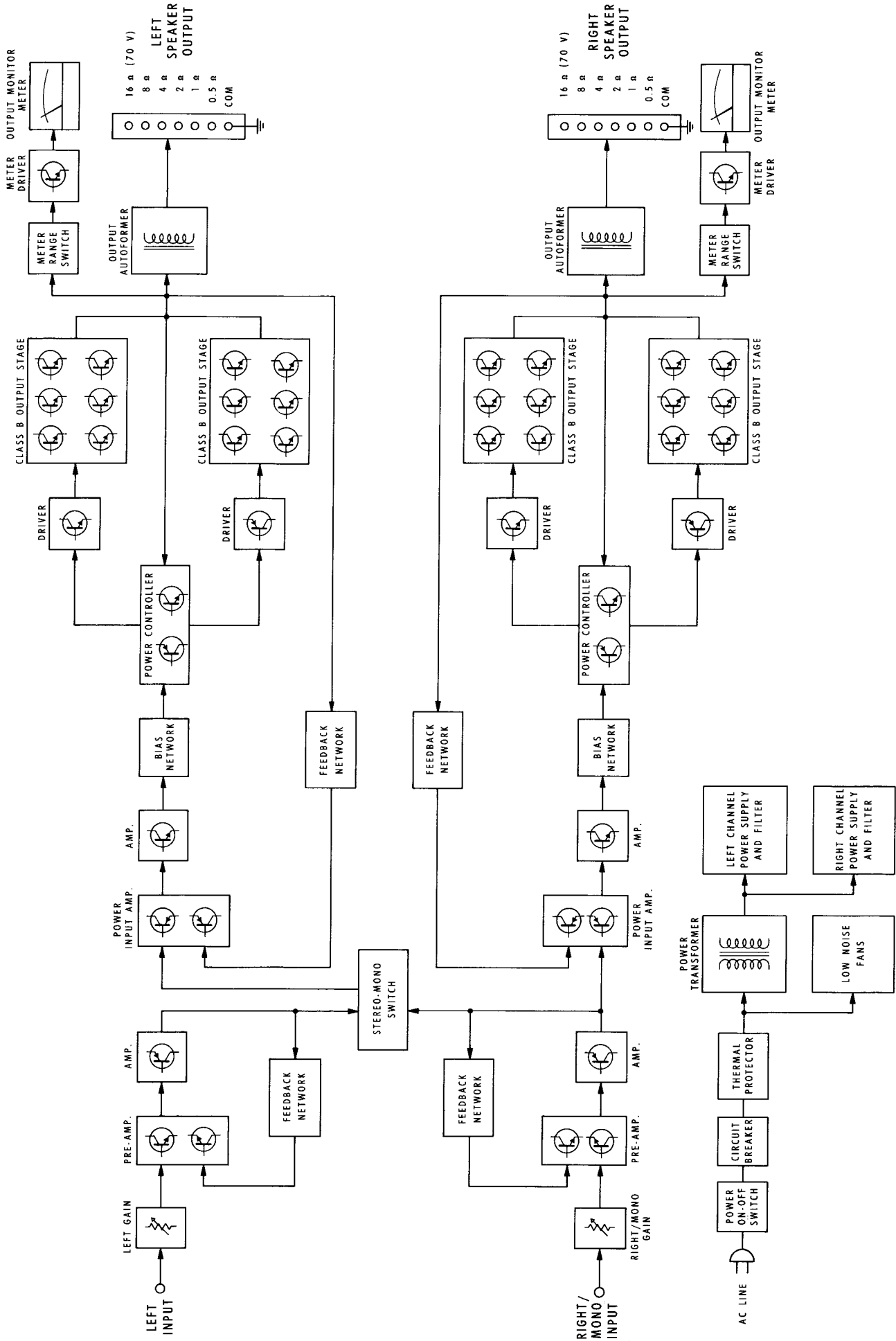

MC 2300 BLOCK DIAGRAM

INPUT SECTION PRINTED CIRCUIT BOARD 044-331

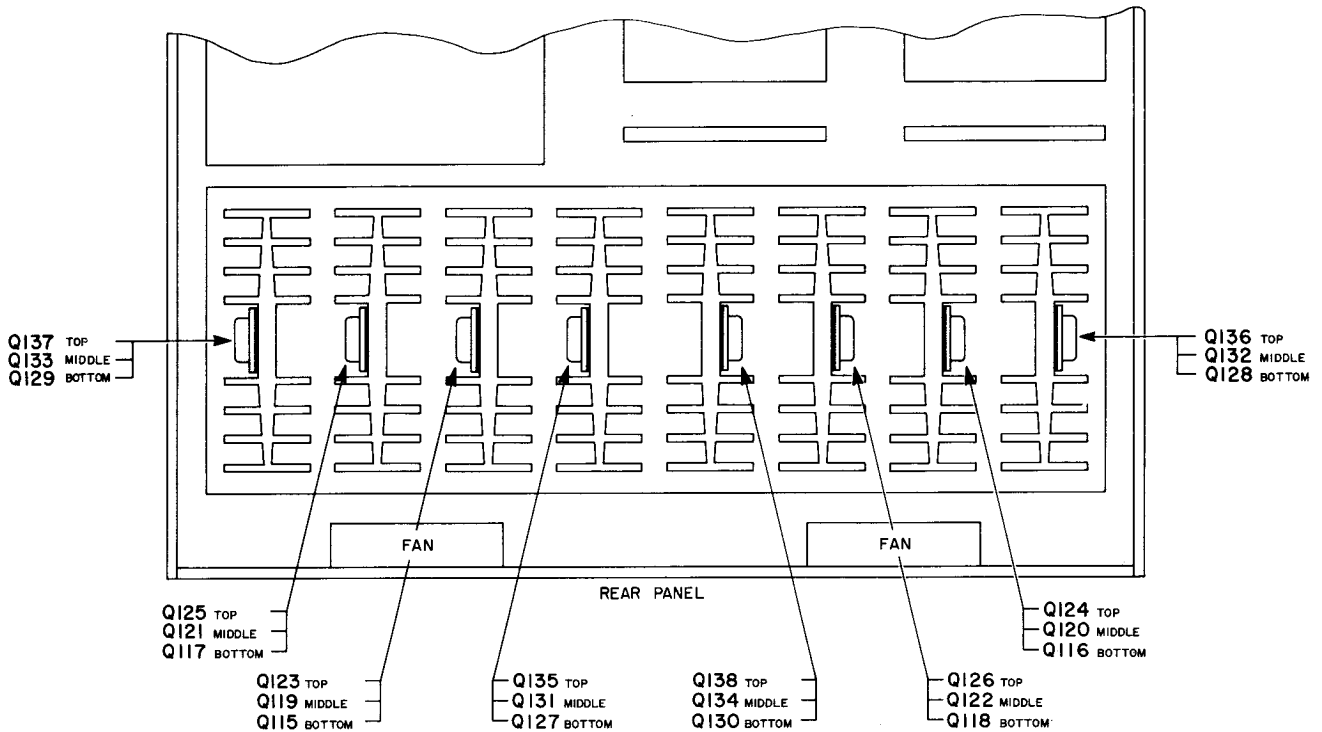
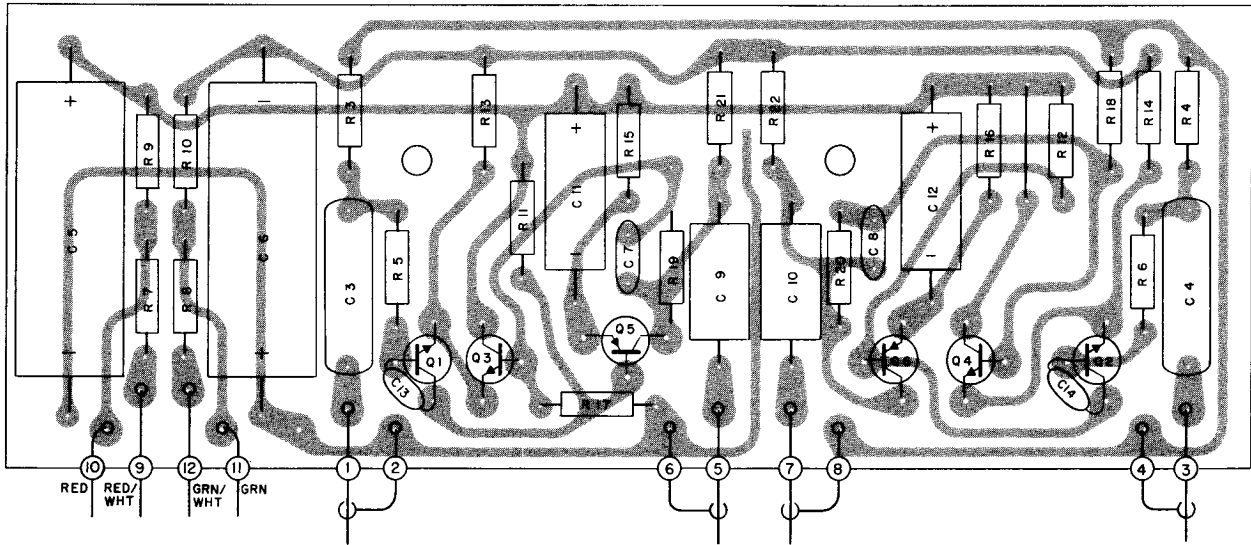

LOCATION OF TRANSISTORS NOT ON PC BOARDS

INPUT PC BOARD 044-331

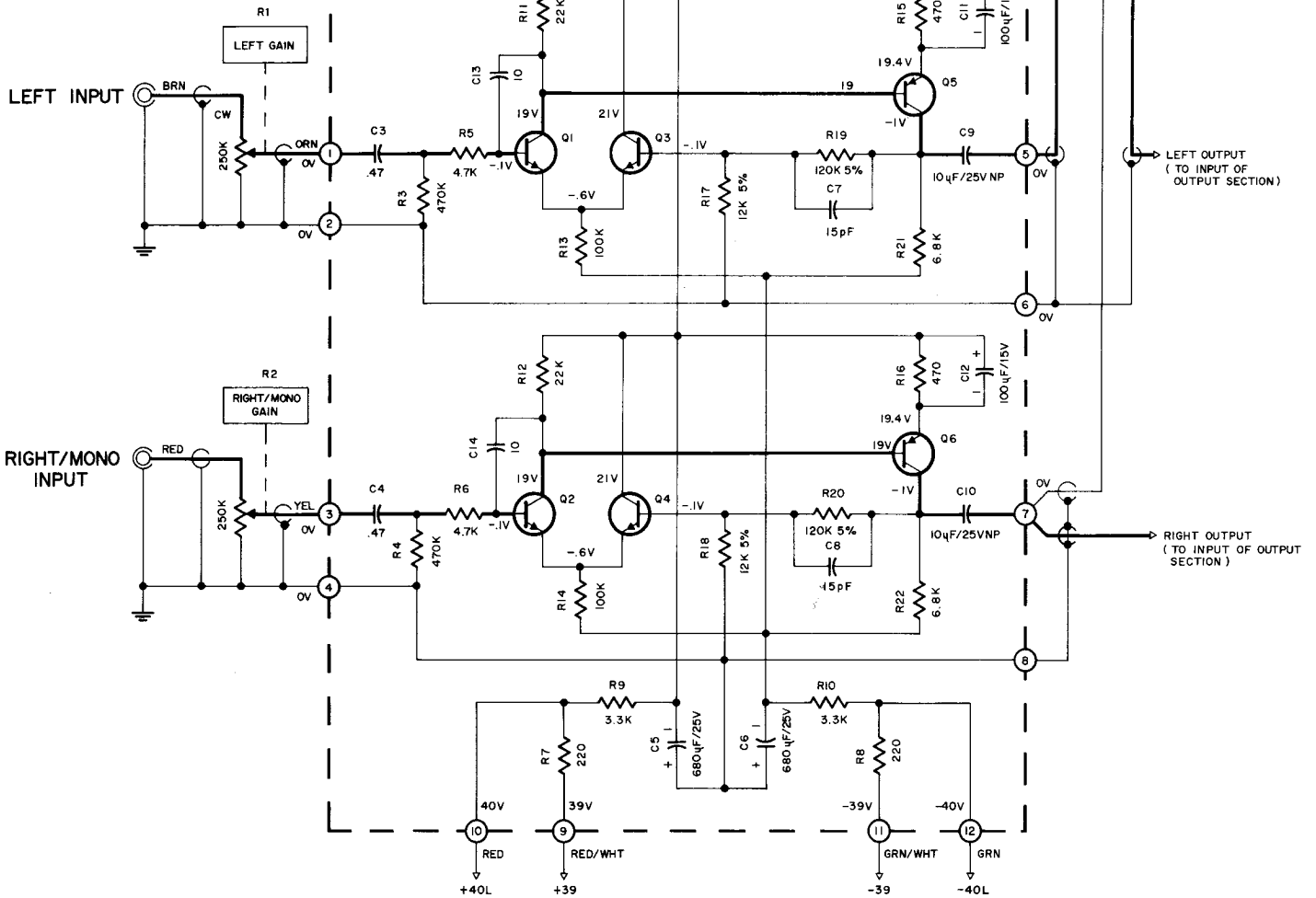

INPUT SECTION

LEFT CHANNEL POWER OUTPUT PRINTED CIRCUIT BOARD 044-243

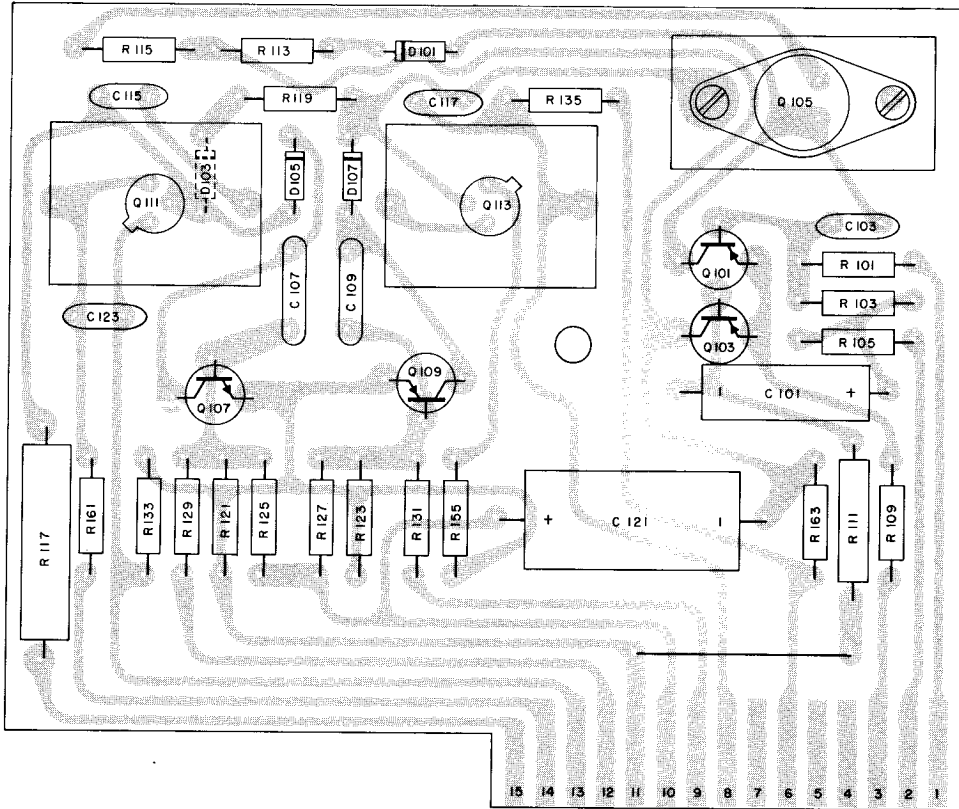

RIGHT CHANNEL POWER OUTPUT PRINTED CIRCUIT BOARD 044-243

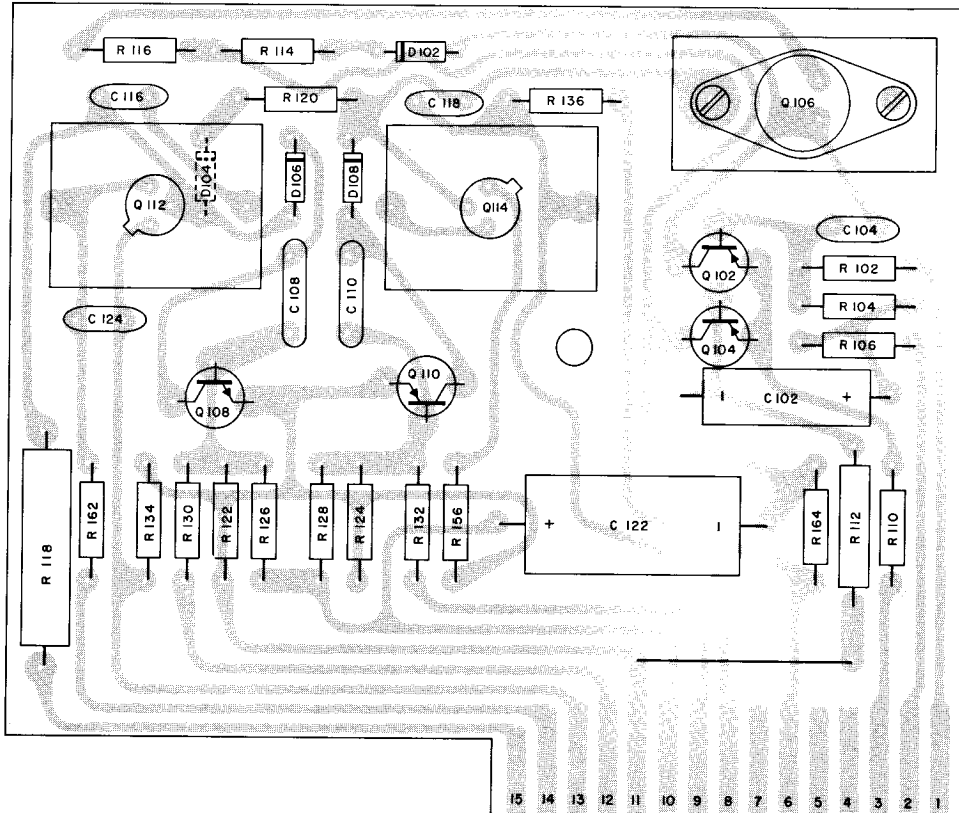

OUTPUT PC BOARD 044-243

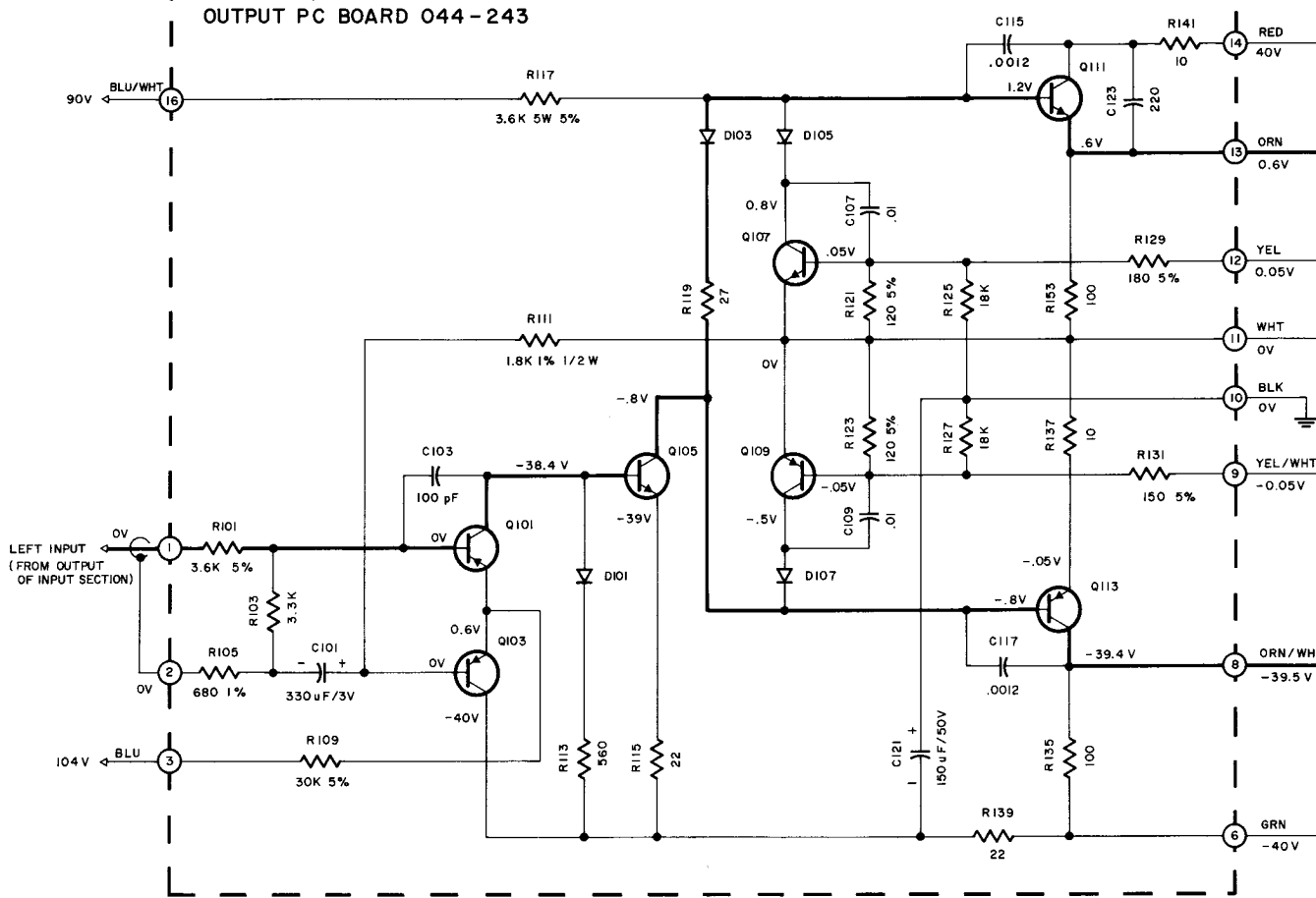

OUTPUT PC BOARD 044-243

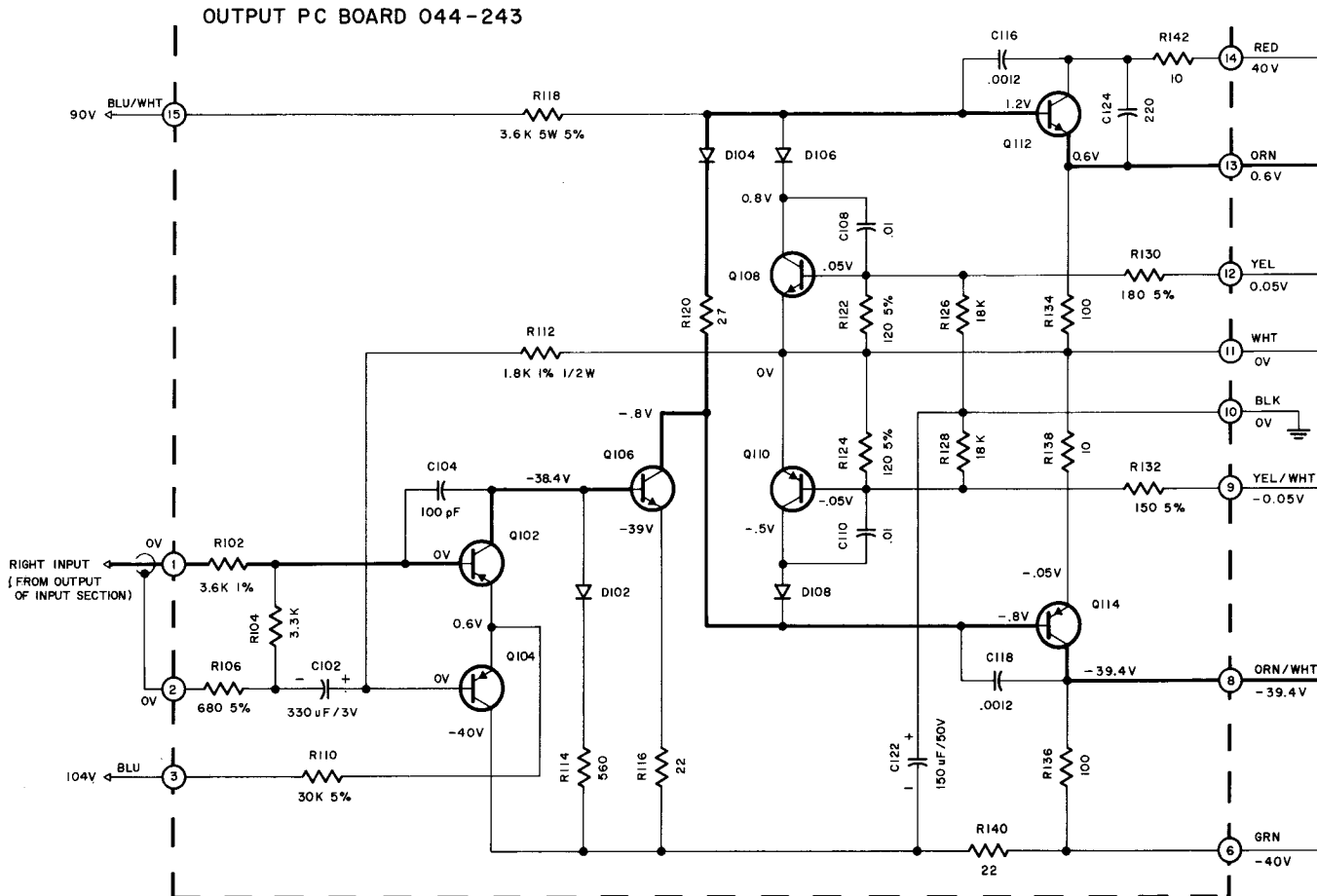

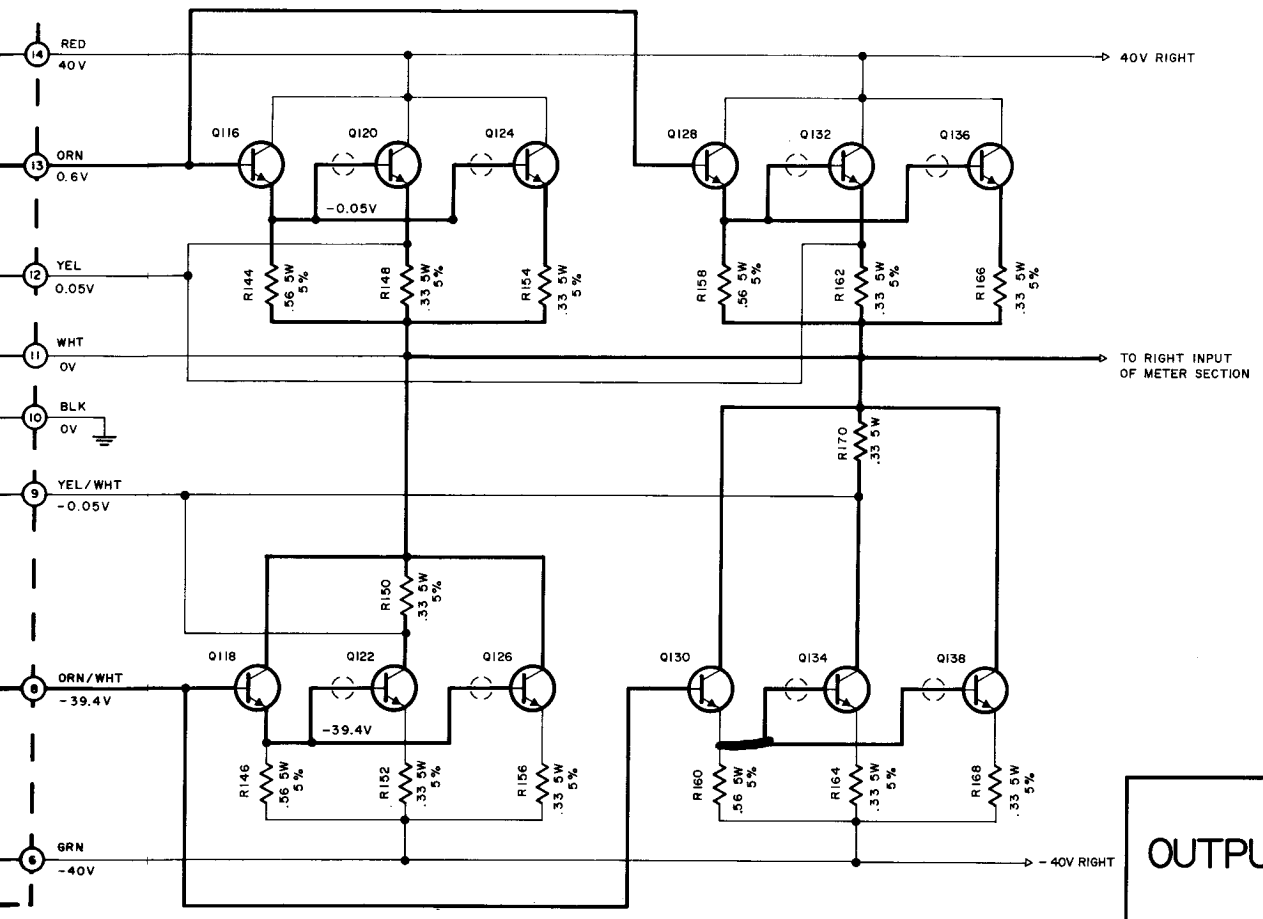
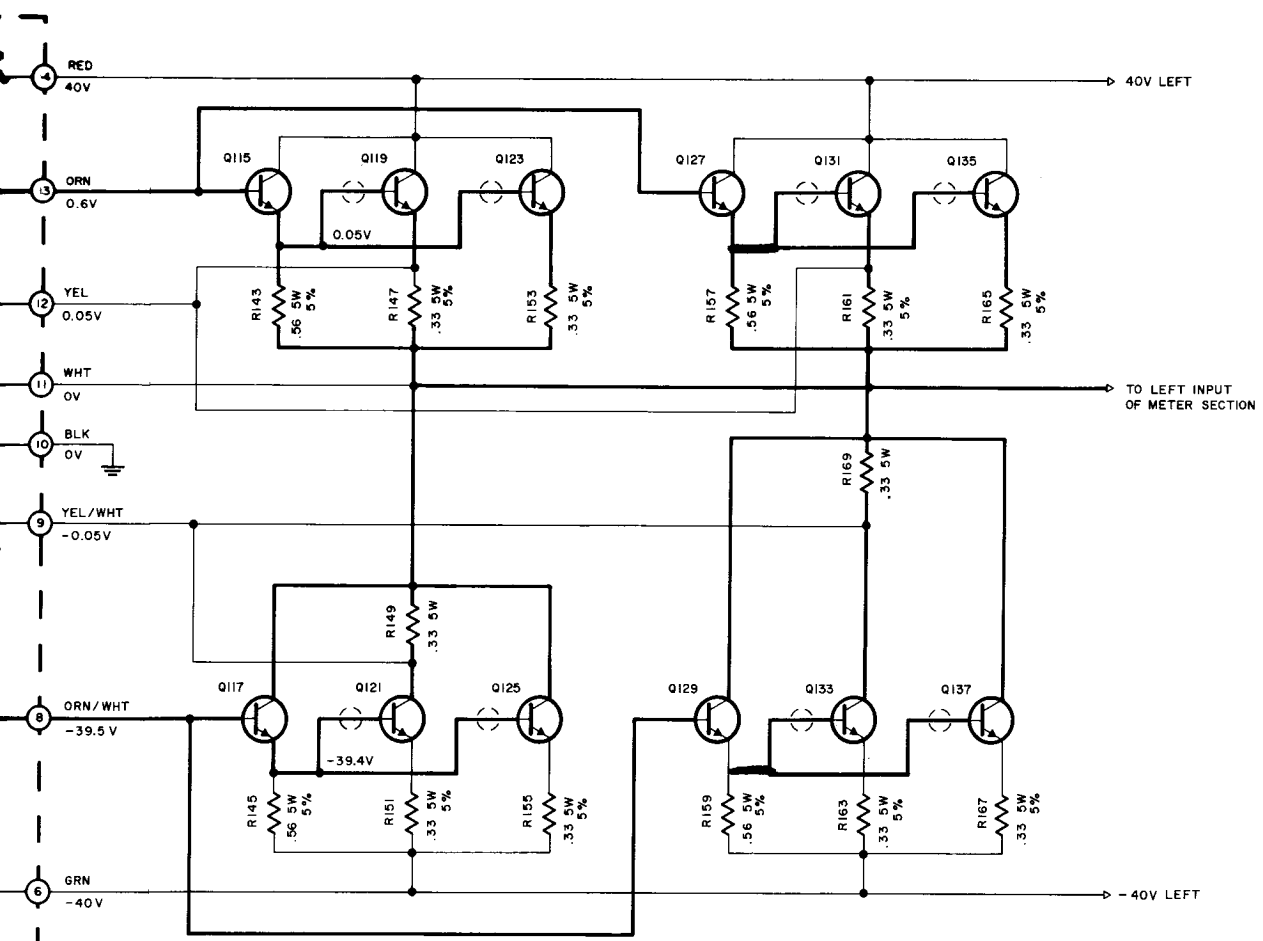

OUTPUT SECTION
 MC 2300
 154 - 455

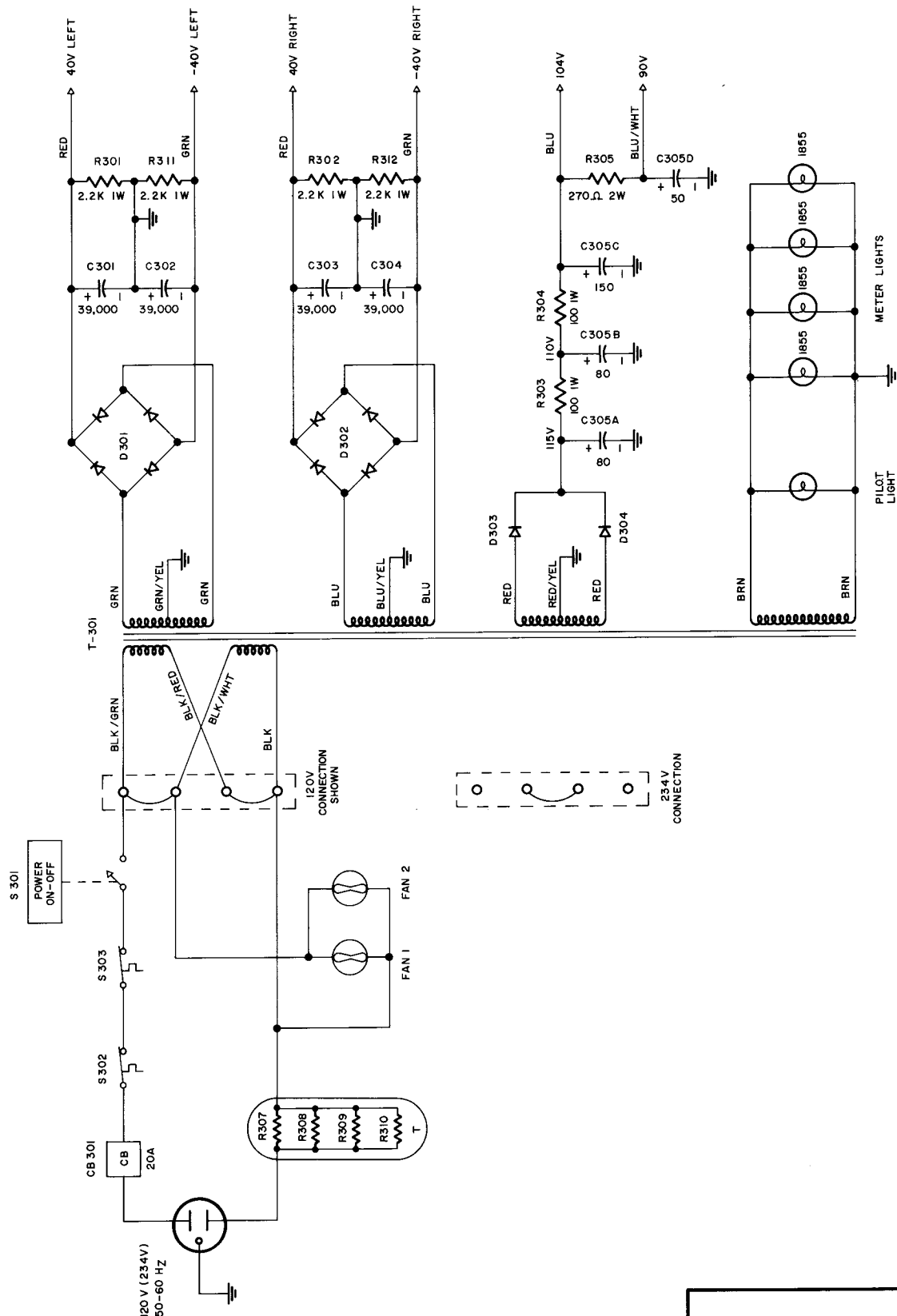

POWER SUPPLY SECTION

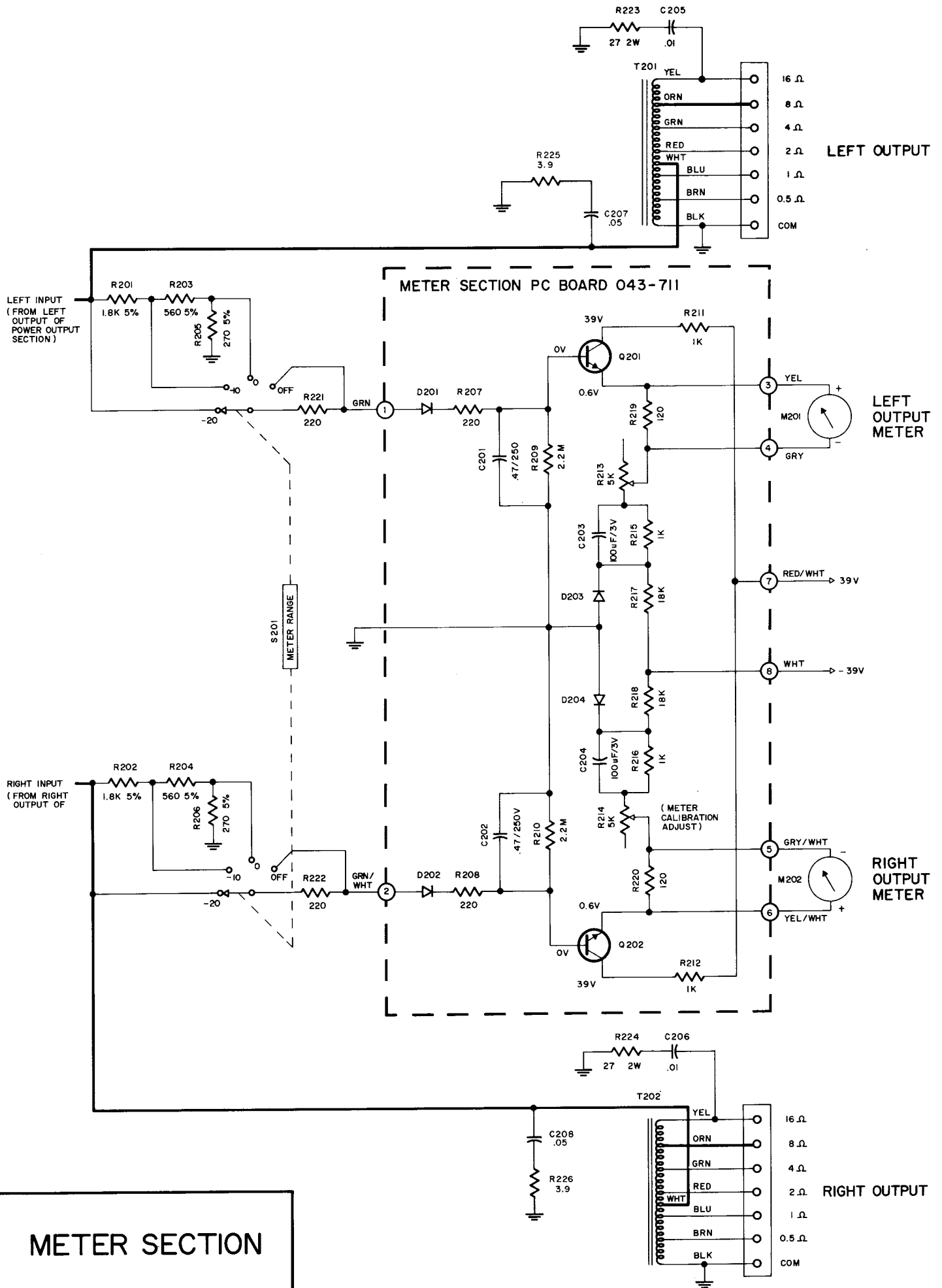

METER SECTION

1. Unless otherwise specified: Resistance values are in ohms, 1/2 watt, and 10% tolerance; capacitance values smaller than 1 are in microfarads (μF); capacitance values greater than 1 are in picofarads (pF); inductors are in microhenries (μH).
2. Printed circuit board components are outlined on the schematics by dotted lines. The circled numbers on the dotted lines correspond to the numbers on the PC board layouts.
3. The heavy lines on the schematics denote the primary signal path.
4. The terminal numbering of rotary switches is for reference only.
5. All voltages indicated on the schematics are measured under the following conditions:
 - a. Use of an 11 megohm impedance VTVM.
 - b. All voltages $\pm 10\%$ with respect to chassis ground.
 - c. No signal at input terminals.
 - d. AC input at 120 volts AC, 50/60Hz.
 - e. Front panel controls at:

Left Gain	FULLY CCW
Meter Range	FULLY CCW
Right/Mono Gain	FULLY CCW
Power	ON

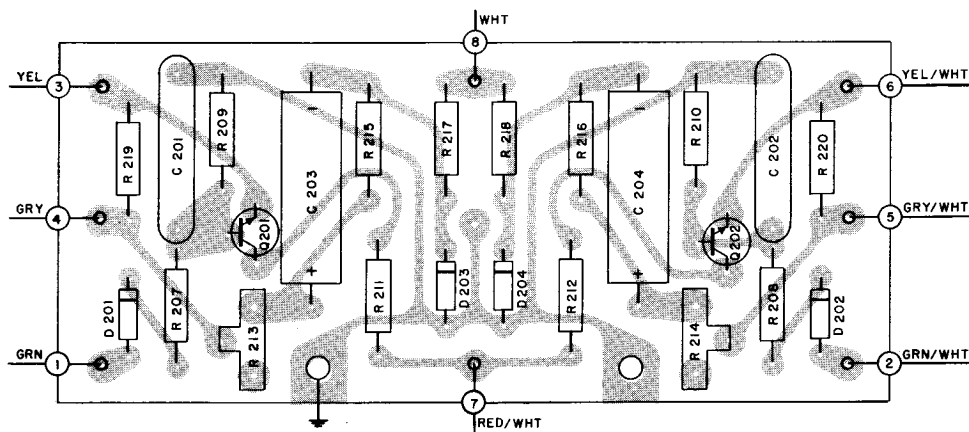

METER SECTION PRINTED CIRCUIT BOARD 043-711

REPLACEMENT PARTS

All parts not listed are common items obtainable from radio parts jobbers.

Replacement parts may be obtained when ordered by PART NUMBER from:

McIntosh Laboratory, Inc.
Customer Service Department
2 Chambers Street
Binghamton, New York 13903
(telephone 607-723-3512)

CAPACITORS

Symbol Number	Description	Part Number
C3,4	Mylar .47 μ F 250V	064-045
C5,6	Elect. 640 μ F 25V	066-157
C9,10	Elect. 10 μ F 25V	066-005
C11,12	Elect. 100 μ F 15V	066-127
C101,102	Elect. 330 μ F 3V	066-105
C121,122	Elect. 150 μ F 50V	066-152
C201,202	Mylar .47 μ F 250V	064-045
C203,204	Elect. 100 μ F 3V	066-047
C301,302	Elect. 3900 μ F 40V	066-119
C303,304	Elect. 3900 μ F 40V	066-119
C305	Elect. 80/80/150/50 μ F 200/200/150/150V	066-095

DIODES

D101,102	Si. signal diode	070-022
D103,104	Si. reference diode	070-040
D105,106	Si. signal diode	070-022
D107,108	Si. signal diode	070-022
D201,202	Ge. signal diode	070-052
D203,204	Ge. signal diode	070-052
D301,302	Rectifier bridge	070-050
D303,304	Si. rectifier	070-031

TRANSISTORS

Q1,2	Si. NPN transistor	132-054
Q3,4	Si. NPN transistor	132-054
Q5,6	Si. PNP transistor	132-056
Q101,102	Si. PNP transistor	132-056
Q103,104	Si. PNP transistor	132-056
Q105,106	Si. PNP transistor	132-028
Q107,108	Si. NPN transistor	132-021
Q109,110	Si. PNP transistor	132-032
Q111,112	Si. NPN transistor	132-038
Q113,114	Si. PNP transistor	132-039

Q115,116	Si. NPN transistor	132-070
Q117,118	Si. NPN transistor	132-070
Q119,120	Si. NPN transistor	132-070
Q121,122	Si. NPN transistor	132-070
Q123,124	Si. NPN transistor	132-070
Q125,126	Si. NPN transistor	132-070
Q127,128	Si. NPN transistor	132-070
Q129,130	Si. NPN transistor	132-070
Q131,132	Si. NPN transistor	132-070
Q133,134	Si. NPN transistor	132-070
Q135,136	Si. NPN transistor	132-070
Q137,138	Si. NPN transistor	132-070
Q201,202	Si. NPN transistor	132-054

POTENTIOMETERS

R1	Left gain control	134-233
R2	Right/Mono gain control	134-233
R213,214	Meter adjust	134-120

RESISTORS

R117,118	Wirewound 3.6k 5% 5W	139-065
R143,144	Wirewound .56 Ω 5W	139-081
R145,146	Wirewound .56 Ω 5W	139-081
R147,148	Wirewound .33 Ω 5W	139-080
R149,150	Wirewound .33 Ω 5W	139-080
R151,152	Wirewound .33 Ω 5W	139-080
R153,154	Wirewound .33 Ω 5W	139-080
R155,156	Wirewound .33 Ω 5W	139-080
R157,158	Wirewound .33 Ω 5W	139-080
R159,160	Wirewound .33 Ω 5W	139-080
R161,162	Wirewound .33 Ω 5W	139-080
R163,164	Wirewound .33 Ω 5W	139-080
R165,166	Wirewound .33 Ω 5W	139-080
R167,168	Wirewound .33 Ω 5W	139-080
R307,308	Thermistor	144-012
R309,310	Thermistor	144-012

METERS

M201,202	Meter (Power level)	124-018
----------	---------------------	---------

SWITCHES

S1	Mono/Stereo switch	148-019
S201	Meter range switch	146-152

S301	Power on-off switch	153-012
S302,303	Thermal cut-out	153-007

TRANSFORMERS

T201,202	Audio autoformer	044-244
T301	Power transformer	044-242

CIRCUIT BREAKER

CB301	Circuit breaker 20A	088-006
-------	---------------------	---------

LAMPS

#1866 (meter)	058-014
Pilot lamp	058-040

FRONT PANEL & TRIM

Front panel	002-345
Side frame (right)	043-830
Side frame (left)	043-831
Handles	020-028
Left gain knob	090-106
Right/Mono gain knob	090-106
Meter range knob	090-106
Meter bezel	020-022

MISCELLANEOUS ITEMS

Shipping carton	044-
Owners manual	038-495
AC line cord	170-038
Hardware package	044-240
Cooling fan	098-144
Cooling fan guard	098-143

MC 2300

SCHEMATIC PART NO. 038-496